

正面吊运机

REACH  
STACKER

ISO 9001 认证

HELI  
中国合力 提升未来



正面吊运机  
REACH STACKER

设计印刷 孚可立印务 Fokeeli Print 180228



安徽合力股份有限公司  
ANHUI HELI CO., LTD.

地址: 合肥市经开区方兴大道668号  
咨询电话: 0551-63689111  
融资租赁: 0551-63689365  
传真: 0551-63689365  
网址: <http://www.helichina.com>  
邮箱: [sale@helichina.com](mailto:sale@helichina.com)

ADD: NO. 668 Fangxing Street, Economical Development Zone, Hefei, P.R. China  
TEL: (86 55 1) 63639068 (America) 63639258 (Europe) 63639358 (Asia)  
63662105 (Africa & Middle East) 63639530 (Warehouse Equipment)  
63639531 (Wheel loader)

FAX: (86 55 1) 63639966  
WEBSITE: <http://www.helichina.com>  
Email: [helih@helichina.net](mailto:helih@helichina.net)



我们的实力  
Our strength

安徽合力股份有限公司系安徽叉车集团有限责任公司核心控股子公司，1996年在上海证券交易所上市，注册资本6.168亿元，是我国目前规模最大、产业链条完整、综合实力和经济效益好的工业车辆研发、制造与出口基地。

作为中国最大的叉车品牌，安徽叉车集团秉承“以人为本，以精品回报社会”的核心价值观，致力于为用户提供高效、便捷的物流解决方案，以前瞻科技提升品质，为用户创造价值。

合力正面吊，您最佳的物流解决方案。

Anhui heli co., LTD. Department of anhui forklift group limited liability company core subsidiary, listed on the Shanghai stock exchange in 1996, the registered capital of 616.8 million yuan, is our country at present, large scale and complete industry chain, good economic performance and comprehensive strength industrial vehicle research and development, manufacture and export base.

As the largest forklift truck brand in China, Anhui Forklift Truck Company adheres to core value of “people-oriented, reciprocate the society with refined product” and is committed to provide customer with high efficient and fast logistic solution and create value for customer through improving quality with advanced technology.

HELI reach stacker is your best logistic solution.



行业地位  
Industry status

公司的叉车和零部件产品在国内同行业中规格最全、规模最大，叉车的综合性能处于国内同行业龙头地位，部分产品达到国际先进水平。各项主要经济指标已连续多年高居全国同行业之首。

Forklift and parts of products of the company in the country the most complete specifications and in the industry, the comprehensive performance of forklift truck in a domestic same industry leading position, some products reached the international advanced level. The main economic indicators has been for many years in the industry to high.



科研实力  
The scientific  
research strength

公司技术中心是1995年由国家发改委等四部委首批认定的100家国家级“企业技术中心”之一。学科齐全，基础设施雄厚。

Company technology center is in 1995 by the national development and reform commission, the four ministries and commissions such as the first wave of 100 identified one of the state-level enterprise technology center. Discipline is complete, the infrastructure is strong.

我们的实力  
Our strength



重要奖项  
Important awards

近5年，公司自主研发的新产品获得6项科技进步奖，安徽省科技进步一等奖2项，机械工业科技进步二等奖一项。

In recent five years, the company independent research and development of new products to get six progress prize in science and technology, anhui science and technology progress award two, science and technology progress prize of mechanical industry.

## A. 高设计标准 High design standard

- ▶ 合力正面吊整机开发采用全数字化三维设计，车架、伸缩臂等关键零部件均经CAE有限元分析、模态分析、动力学仿真分析等优化设计手段，以精准的理论数据作为设计基础，确保整车性能。设计方案成熟可靠，与欧洲同类产品水平同步，设计标准不仅满足国家标准GB/T26474-2011，同时满足欧盟标准EN1459和ISO15018标准。
- ▶ Truck performance is ensured with accurate theoretic data as design basis through CAE analysis, finite element analysis, modal analysis and dynamics simulated analysis on key parts like frame, telescopic boom and so on and full digitalized 3D software during truck development. The design scheme of the completed truck is mature and reliable and achieves same performance level as the same product in European market. Not only China design standard GB/T26474-2011 is satisfied, EN1459 and ISO 15018 design standards are also satisfied.



European Alliance  
CE Certificate  
欧盟CE认证

## B. 齐全系列 Complete series

- ▶ 合力集装箱正面吊产品，是合力与欧洲知名港口机械设计公司联合开发，用于20'、40'满载集装箱的搬运及堆垛，广泛应用于港口、码头、铁路系统及集装箱中转站等场所。合力正面吊具有齐全系列，可靠地安全性能，优异的节能环保性和高效作业的特点。整机拥有电控超载保护系统，自动灭火系统，倒车集成监控系统等，产品各项性能指标世界领先，是您最佳的选择。
- ▶ HELI co-develops reach stacker with EURO famous port machinery design company for handling and stacking 20 foot and 40 foot fully loaded container. It is widely used in port, dock, railway system, container terminal and so on. HELI reach stacker has the characteristics of complete series, reliable safety performance, good energy saving and environmental protection performance and high working efficiency. The truck is assembled with electric controlled overload protection system, automatic fire extinguishing system, backward integrated monitoring system and so on. The truck has world leading performances and it is your best choice.



## C. 可靠的质量 Reliable quality

### ▶ 电控超载保护系统

通过智能超载保护系统，自动识别桥体转向角度，调整吊具伸缩状态，确保整车在安全的起吊范围内起升，大大提高了作业的安全性和作业效率。

### ▶ Electric controlled overload protection system

Intelligent overload protection system can automatically detect axle steering angle and adjust spreader state to ensure lifting within safety range. And thus working safety and working efficiency is largely improved.

### ▶ 倒车集成监控系统

倒车集成监控系统的应用，可以随时监控车体周围安全状况，保证车辆的安全操作行驶，极大的提高了整车的作业安全性。

### ▶ Backward integrated monitoring system

Backward integrated monitoring system can monitor the safety around the truck at any time to ensure truck safety driving.

### ▶ 整机防火控制系统(选配)

车体内关键位置安装强力自动灭火系统，实现防火预报警，阻燃及灭火功能，防火控制安全可靠。

### ▶ Truck fire extinguishing control system (Optional)

Powerful automatic fire extinguishing system is installed in the key position of the truck achieving fire pre-alarm, antflaming and fire extinguishing functions. It is safe and reliable.

### ▶ 真空胎柔性减震技术

选用缓冲功能较好的真空胎减震技术，降低车体与地面的冲击接触，作业更安全，操作更舒适，且维修保养成本低，大大提高了设备的结构件的使用寿命。

### ▶ Vacuum pneumatic tyre

Vacuum pneumatic tyre with good buffering function reduces shock contact between truck and ground. It is safer and more comfortable. What is more, maintenance cost is largely reduced and structural parts service life is largely increased.



### ▶ 可靠的动力系统

选用原装进口VOLVO/CUMMINS等世界知名品牌发动机，动力强劲，质量可靠。结合先进的动力匹配技术及控制技术，使整车动力性能得到最大的释放。

### ▶ Reliable power system

Imported VOLVO/CUMMINS engine with original packing is assembled on the truck. It is powerful and reliable. Combined with advanced power matching technology and control technology, truck performance is brought into full play.



### ▶ 可靠的结构设计

整机开发采用全数字化三维设计系统，经CAE有限元分析、模态分析、动力学仿真分析等优化设计手段，以精准的理论数据作为设计基础，确保整车性能。设计方案成熟可靠，与欧洲同类产品水平同步，设计标准不仅满足国家标准GB/T26474-2011，同时满足欧盟标准EN1459和ISO15018标准。

### ▶ Reliable structure design

Truck performance is ensured with accurate theoretic data as design basis through CAE analysis, finite element analysis, modal analysis and dynamics simulated analysis on key parts like frame, telescopic boom and so on and full digitalized 3D software during truck development. The design scheme of the completed truck is mature and reliable and achieves same performance level as the same product in European market. Not only China design standard GB/T26474-2011 is satisfied, EN1459 and ISO 15018 design standards are also satisfied.

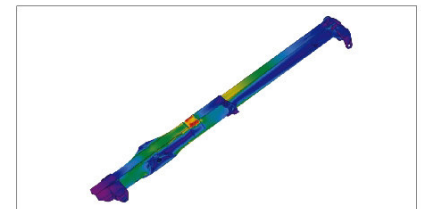
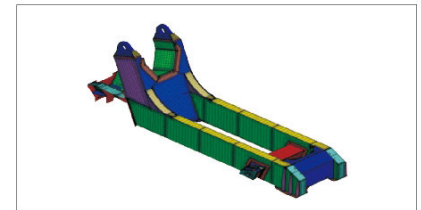

## D. 高效的作业 High efficient working

## ▶ 能量再生技术

全过程“能量再生”自动控制功能让大臂在起升过程中，变幅油缸上腔的回油直接利用于起升，起升速度更快、更高效。

## ▶ Energy regenerating technology

Big arm oil cylinder overall process “energy regenerating” automatic controlling function uses the return oil in the cylinder upper cavity for lifting and thus offers faster lifting speed and higher efficiency.

## ▶ 垂直升降功能

组合式“垂直升降”自动控制功能，可让大臂同时实现伸缩、升降功能，简化驾驶员操作，保障安全同时提升工作效率。

## ▶ Vertical lift function

Big arm stretching out and drawing back function and lifting and lowering function can be realized simultaneously with combined type “vertical lift” automatic control function. And thus working efficiency is improved.

## ▶ 舒适的操作环境

方便的人机交互式操作界面，操作者可以实时掌控整车的运行状态；宽阔的操作视野，全悬浮式可调座椅等，大大提高了操作者的舒适性，降低操作疲劳，提高工作效率。

## ▶ Comfort operation environment

Through convenient man-machine interactive operation interface, operator can control truck real time working state. Wide view and fully suspension adjustable seat improve operator comfort, reduce operation fatigue and increase working efficiency largely.

▶ 集装箱吊运统计及打印系统（选配）  
办公化配件提升日常作业管理效率。▶ Container stacking statistics and print system  
(optional)  
Official configuration improves daily working management efficiency.

## E. 低使用成本 Low cost

- ▶ **节能的动力系统**  
完美的动力系统匹配，可以根据负载变化自动识别动态功率，调节发动机转速，充分发挥整机作业效率高、低油耗的特性。
- ▶ **Energy saving power system**  
Perfect power system matching can automatically identify dynamic power according to the change of load, adjust engine speed and bring truck high working efficiency and low oil consumption performance into full play.

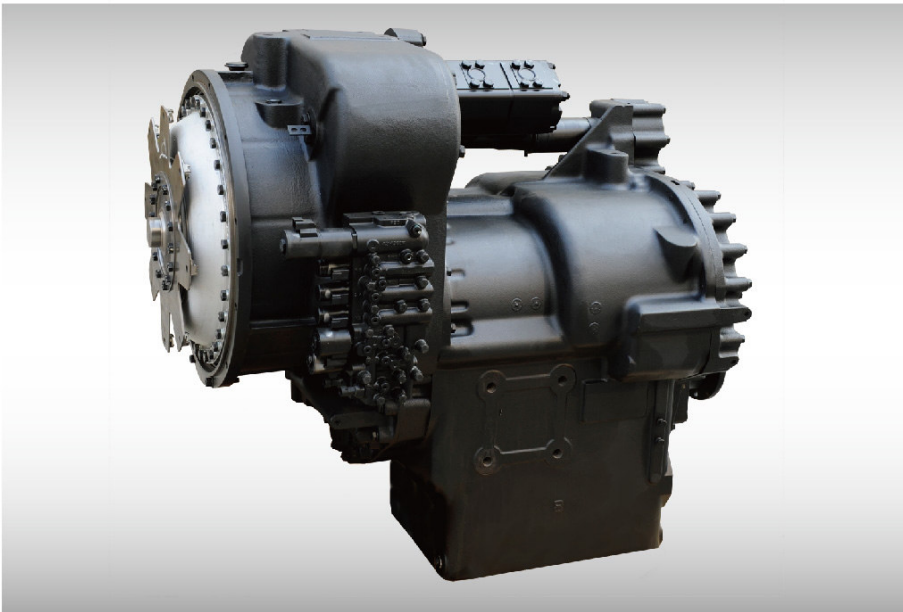

- ▶ **液压负荷感应系统**  
根据实际负载，调节油泵输出流量，实现流量高精度控制，减少发动机负荷，节能降耗效果显著。
- ▶ **Hydraulic load sensing system**  
Hydraulic load sensing system can adjust oil pump output flow according to actual load and achieve high precision control on flow. And thus engine load is reduced and truck oil consumption is reduced.
- ▶ **真空胎柔性减震技术**  
选用缓冲功能较好的真空胎减震技术，降低车体与地面的冲击接触，作业更安全，操作更舒适，且维修保养成本低。
- ▶ **Vacuum pneumatic tyre**  
Vacuum pneumatic tyre with good buffering function reduces shock contact between truck and ground. It is safer and more comfortable. What is more, maintenance cost is largely reduced and structural parts service life is largely increased.
- ▶ **LED照明系统**  
采用LED高亮度、低能耗照明系统，为夜间工作提供更好的照明环境和日间行车指示。
- ▶ **LED lighting system**  
LED lighting system which is bright and has low energy consumption offers better lighting for working and indication.



## F. 便捷的维修 Easy maintenance



- ▶ **全包围防滑上下车安全通道**  
通过防滑上下车安全通道系统，可以安全快速地到相关操作区域，大大提高操作的便捷性。
- ▶ **Fully surrounded anti-skidding getting on and off safety passway**  
You can reach to the area needs repair safely and quickly through fully surrounded anti-skidding getting on and off safety passway and thus repair is more convenient.
- ▶ **外置式维护保养检查机构**  
采用车体外置式燃油滤清器及液压油滤清和滤芯布置，极大的方便车辆的日常维护保养，缩短了维护保养操作时间，提高车辆维护效率。
- ▶ **Outside installed maintenance and repair check mechanism**  
Outside installed fuel filter, hydraulic oil filter and filter core facilitate daily maintenance, shorten maintenance time and improve truck maintenance efficiency.

- ▶ **集中润滑系统**  
关键运动部件采用集中润滑系统，大大提升维护的方便性和部件的更换周期；
- ▶ **Centralized lubricating system**  
Centralized lubricating system makes maintenance easy and extends parts service life.
- ▶ **备件库遍布世界各地**  
备件可快速提供无论你身处何方。备件可由本地的合力销售网点或代理商快速提供，或直接从公司总部仓库发运。
- ▶ **Worldwide spare parts store centers**  
No matter where you are, HELI local sales network or dealers can provide you with spare parts locally or directly from HELI headquarters quickly.



## G. 吊具选配 Spreader



- ▶ 采用世界著名专业吊具生产厂家——瑞典ELME（艾尔玛）公司的817型吊具，该吊具是为正面吊运机特殊的作业工况而专门设计的产品，整体采用优质钢制造，单筒式结构，强度高，视野好。
- ▶ 817 type spreader from world famous spreader manufacturer——Sweden ELME is assembled on the truck. The spreader is specially designed for reach stacker. The spreader is made by high-quality steel and it has single-cylinder type structure, high strength and good view.



## H. 升级驾驶室 Improved driver's cab

- ▶ 标准型正面吊采用全新设计的驾驶室，超大弧面玻璃提供宽阔视野。

Newly designed cab is standard configuration of the reach stacker. Oversized cambered glass on the cab offers wide view.



- ▶ 面板按键排布符合人体工学，保证了充分舒适的操作空间。

The buttons' layout on panel satisfies ergonomics requirements and ensures comfort operation space.





- ▶ 方便美观的人机交互式操作界面，操作者可以实时掌控整车的运行状态。
- ▶ Through convenient and beautiful man-machine interactive operation interface, operator can control truck real time working state.



- ▶ 全悬浮式可调节座椅等，大大提高了操作者的舒适性，降低操作疲劳，提高工作效率。
- ▶ 全封闭设计隔音防震，驾驶室内噪音可低至70dB。
- ▶ 驾驶室内配备灭火装置，保证安全无虞。
- ▶ Fully suspended adjustable seat largely improves operator comfort, reduces operation fatigue and improves working efficiency.
- ▶ Fully enclosed design improves sound insulation and vibration proof performance and noise inside of the cab is reduced to 70dB.
- ▶ Fire extinguisher is equipped in the cab to ensure safety.



载荷图 Load diagram

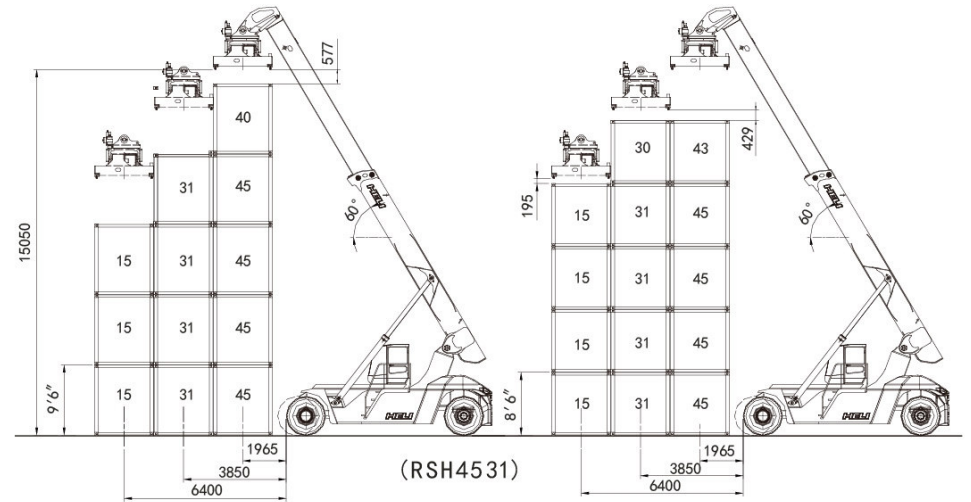
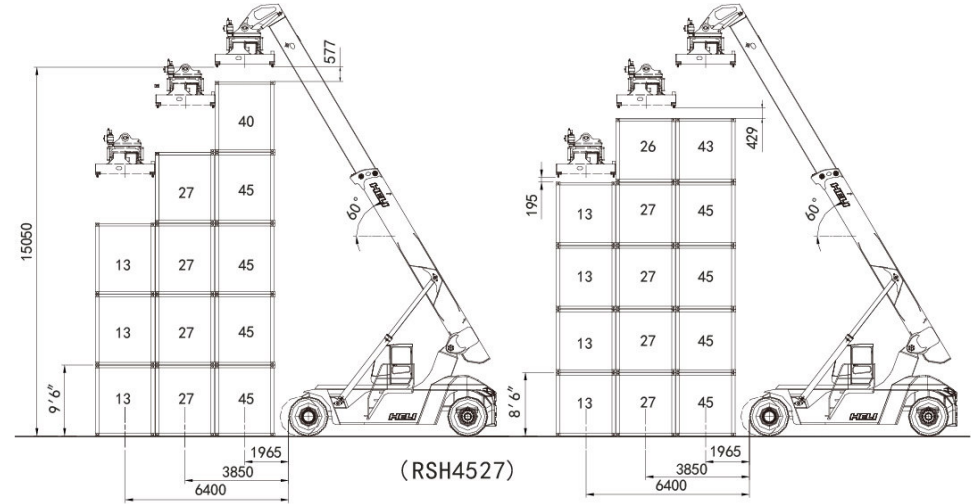

性能参数 Performance specifications				
型号 Model			RSH4527-VO3/VO4/VO5	RSH4531-VO3/VO4/VO5
起重量 Lifting capacity	第一排/第二排/第三排 First row/second row /third row	Kg	45000/27000/13000	45000/31000/15000
载荷中心 Load center	第一排/第二排/第三排 First row/second row /third row	mm	1965/3850/6400	1965/3850/6400
最大起升高度(第一排) Max. lifting height (first row)		mm	15050	15050
集装箱吊具 Container Spreader	侧移 Side shift	mm	± 800	± 800
	旋转 Rotation	°	-105° ~+195°	-105° ~+195°
最小转弯半径R2 Min. turning radius		mm	7990	7990
吊臂最大倾角 Spreader max. tilting angle		°	60	60
轴距 L1 Wheel base		mm	6000	6000
轮距(前W1/后W2) Tread (front/rear)		mm	3030/2838	3030/2838
长度 L Length		mm	11300	11300
宽度 W Width		mm	4148	4148
高度 H Height		mm	4754	4754
轮胎 Tyre	规格 Specification		18.00-25-40PR	18.00-25-40PR
	(前/后) (Front/rear)		4/2	4/2
发动机 Engine	型号 Model		Volvo TAD1151	Volvo TAD1151
	额定功率/转速 Rated output/Speed	kW/rpm	265/2100	265/2100
	额定扭矩/转速 Rated torque/Speed	Nm/rpm	1785/1316	1785/1316
	尾气排放标准 Emissions standards		欧三/国三	欧三/国三
变速箱(前/后) Transmission box (front/rear)			DANA 3600/TE27	DANA 3600/TE27
驱动桥 Drive axle			Kessler	Kessler

外形尺寸: Formal Size

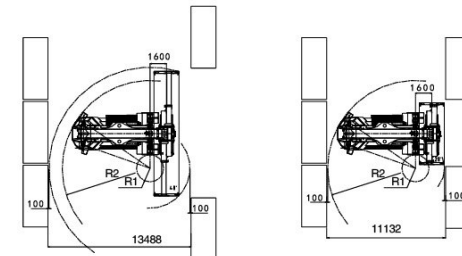
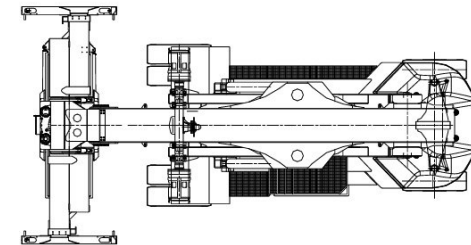
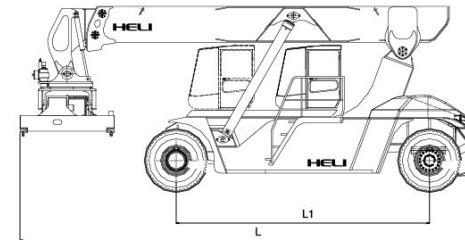
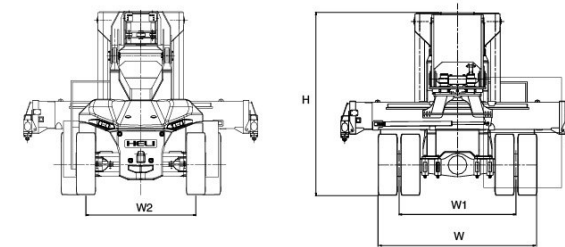

直角通道宽度



附加选配表 Optional

序号 No.	功能 Item	备注 Note
1	集装箱吊运统计及打印系统 container stacking statistics and print system	微型打印机，可打印集装箱重量，箱号及吊箱数量等； Miniprinter: it can print container weight, number and hoisting container quantity.
2	自动灭火系统 Automatic fire extinguishing system	配备热敏感应式干粉灭火器，自动灭火，安全高效； Heat sensitive dry powder extinguisher can extinguish automatically and it is safe and efficient.
3	进口真空胎 Imported vacuum tyre	可根据客户的个性化需求，整车选用进口品牌的真空轮胎； Tyre choice can be customized and imported vacuum tyre is optional.
4	自动润滑系统 Automatic lubricating system	配备润滑泵，定时、定量加注润滑油，便捷高效，关键部件润滑充分，更换周期长。 Lubricating pump is assembled on the truck to add lubricating grease on time with proper quantity to ensure fully lubrication of key parts and extend replace period.
5	集装箱精确称重系统 Container weighting system	集装箱精确称重，满足相关行业要求，提供更好安全保护； Accurate container weighting system meets relative industry's requirement and provide better safe protection.
6	吊具着箱自动上锁 Automatic lock when slings catching container	提升驾驶舒适性，有效提高工作效率的智能化选项； Sling will be locked automatically when catching container. Driving comfort and working efficiency are improved
7	GPS远程管理系统 GPS long distance manage system	可实现车辆的远程定位、运行轨迹和状态监控，以及租赁管理等功能。 GPS long distance managing system can realize truck long distance location, moving trajectory and condition monitoring and leasing managing.



## H. 专业服务 Professional service

- ▶ 合力本着“诚信合作、实现共赢”合作观，为用户提供车辆全程、周密的售前、售中、售后技术支持、培训与服务。我们的目标是要与客户达成长久的合作伙伴关系。  
正确的保养和操作是保障车辆使用寿命，减少设备停工时间的重要前提。我们将提供完善的专业的技术支持确保车辆的高效运转。
- ▶ Heli provides customers with close technical support, training and service before sales, during sales and after sales adhering to the cooperation value of “Good faith cooperation and altogether wins development”. Our object is to reach long term cooperation relationship with customers.  
Correct maintenance and operation is an important precondition to ensure truck service life and reduce truck downtime. We will provide perfect and professional technical support to ensure truck high efficient working.

- **备件库遍布世界各地**  
备件可快速提供无论您身处何方。备件可由本地的合力销售网点或代理商快速提供，或直接从公司总部仓库发运。
- **全球服务机构**  
作为中国最大叉车生产品牌，我们国内和国际的销售网点或代理商服务体系将以至诚的服务满足客户的需要。
- **客户服务**  
“用户至上”是合力追求的市场观，客户可以从合力网点或代理商得到最优秀的服务。提供便捷，灵活专业的服务。
- **技术支持-解决您的需求**  
当您有需求时，我们的技术支持可以提供专业的服务。通过联系我们国内和国际的销售网点或代理商或总部服务部门，您可以找到相应技术专家和具有丰富经验的技术人员为您提供技术支持，解决您的需求。
- **培训**  
通过联系我们国内和国际的销售网点或代理商，根据不同型号的设备，为客户定制了专门的驾驶及维修培训服务。
- **Worldwide spare parts store centers**  
No matter where you are, HELI local sales network or dealers can provide you with spare parts locally or directly from HELI headquarters quickly.
- **Worldwide service network**  
As China largest forklift truck manufacturer, HELI sales network and dealer all over the world meet customers' need with sincere service.
- **Customer service**  
“Customer first” is our market value. Customers can receive most sincere service from HELI network or dealers who will provide fast, flexible and professional service.
- **Technical support to satisfy your need**  
We can provide professional service when you need. Through our worldwide network or dealers or headquarter, we can satisfy your need through our technical experts or technicians with rich experience.
- **Training**  
Through our worldwide network or dealers, we will provide you with customized professional driving and repair trainings according to different truck models.